

Bruciatori di gasolio

Light oil burners

Brûleurs fioul domestique

Ölbrenner

Quemadores de gasóleo

Funzionamento bistadio
Two-stage operation
Fonctionnement à deux allures
Zweistufiger Betrieb
Funcionamiento a dos llamas

COD.	MOD.	TYP.
3473232	RL 28	652 T1
3473233	RL 28	652 T1
3474132	RL 38	653 T1
3474133	RL 38	653 T1
3474332	RL 38	653 T1
3474333	RL 38	653 T1
3474632	RL 50	654 T1
3474633	RL 50	654 T1

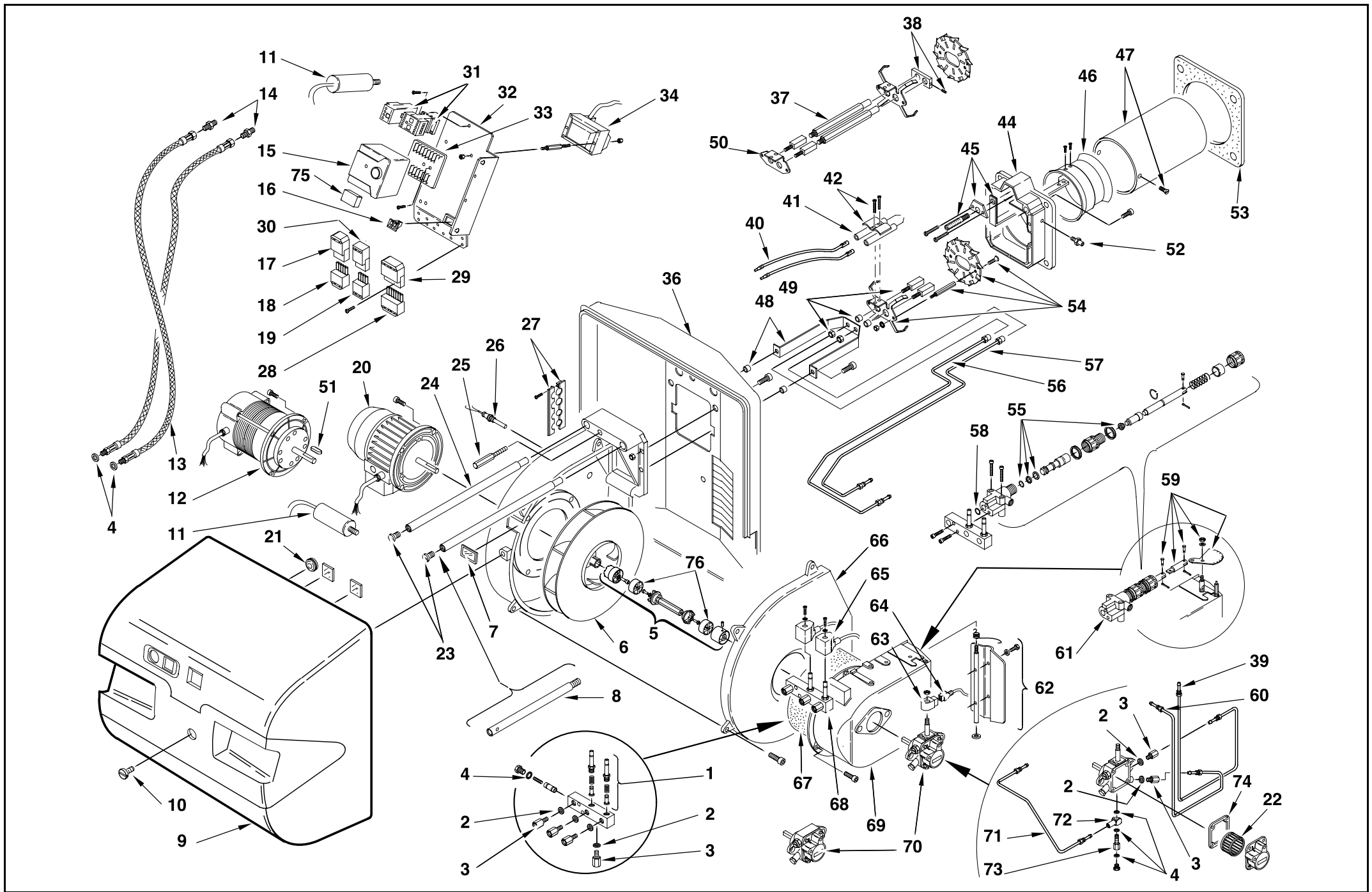

N.	COD.	652T1		653T1		654T1		DESCRIZIONE	DESCRIPTION	DESCRIPTION	BESCHREIBUNG	DENOMINACION	MATRICOLA BR UCIATORE BURNER SERIAL NUMBER MATRICULE BRULEUR BRENNER KENN-NUMMER MATRICULA QUEMADORES	RICAMBI CONSIGLIATI ADVISED PARTS RECHANGE CONSEIL EMPFOHLENE ERSATZTEILE RECAMBIOS A CONSEJADOS
		3473232	3473233 *	3474132	3474133 *	3474332	3474333 *							
1	3005733	•	•	•	•	•	•	VALVOLA	NEEDLE VALVE	ROBINET POINTEAU	NADELVENTIL	VÁLVULA		B
2	3007077	•	•	•	•	•	•	GUARNIZIONE	SEAL	RONDELLE	METALLDICHTUNG	JUNTA		A
3	3006719	•	•	•	•	•	•	RACCORDO	CONNECTOR	MAMELON	NIPPEL	RACORD		C
4	3007079	•	•	•	•	•	•	GUARNIZIONE	SEAL	RONDELLE	METALLDICHTUNG	JUNTA		A
5	3003758	•	•	•	•	•	•	GRUPPO GIUNZIONE	DRIVE COUPLING	ACCOUPEMENT	KUPPLUNG	CONJUNTO		A
6	3003760	•	•					GIRANTE	FAN	TURBINE	GEBLÄSERAD	TURBINA		C
6	3003761			•	•			GIRANTE	FAN	TURBINE	GEBLÄSERAD	TURBINA		C
6	3003762					•	•	GIRANTE	FAN	TURBINE	GEBLÄSERAD	TURBINA		C
7	3003763	•	•	•	•	•	•	VISORE	INSPECTION WINDOW	VEISEUR	SICHTFENSTER	VISOR		
8	3003764	•	•	•	•	•	•	PROLUNGA PERNO	BAR EXTENSION	RALLONGE DE GLISSIERE	VERLÄNGERUNG	PROLUNGACION GUIA		
9	3003765	•	•	•	•	•	•	COFANO	COVER	COFFRET	VERKLEIDUNG	ENVOLVENTE		
10	3003766	•	•	•	•	•	•	VITE	SCREW	VIS	SCHRAUBE	TORNILLO		
11	3006614	•	•					CONDENSATORE	CONDENSER	CONDENSATEUR	KONDENSATOR	CONDENSADOR		B
11	3013577			•	•			CONDENSATORE	CONDENSER	CONDENSATEUR	KONDENSATOR	CONDENSADOR		B
12	3013490	•	•					MOTORE	MOTOR	MOTEUR	MOTOR	MOTOR		C
13	3003769	•	•	•	•	•	•	TUBO FLESSIBILE	FLEXIBLE OIL LINE	FLEXIBLE	SCHLAUCH	TUBO FLEXIBLE		A
14	3009068	•	•	•	•	•	•	RACCORDO	CONNECTOR	MAMELON	NIPPEL	RACORD		C
15	3013071	•	•	•	•	•	•	APPARECCHIATURA	CONTROL BOX	BOITE DE CONTROLE	STEUERGERÄT	CAJA CONTROL		B
16	3003770	•	•	•	•	•	•	INTERRUTTORE	SWITCH	INTERRUPTEUR	SCHALTER	INTERRUPTOR		C
17	3007434			•	•	•	•	PRESA 5 POLI	5 POLE SOCKET	PRISE 5 POLES	STECKERBUCHSE 5 POLEN	CON. MACHO DE 5 CONTAC.		
18	3007589			•	•	•	•	SPINA 5 POLI	5 POLE PLUG	FICHE 5 POLES	STECKER 5 POLEN	CON. HEMBRA DE 5 CONTAC.		
19	3006948	•	•	•	•	•	•	SPINA 4 POLI	4 POLE PLUG	FICHE 4 POLES	STECKER 4 POLEN	CON. HEMBRA DE 4 CONTAC.		
20	3013425			•	•			MOTORE	MOTOR	MOTEUR	MOTOR	MOTOR		C
20	3003772			•	•			MOTORE	MOTOR	MOTEUR	MOTOR	MOTOR		C
20	3003773					•	•	MOTORE	MOTOR	MOTEUR	MOTOR	MOTOR		C
21	3007627	•	•	•	•	•	•	MEMBRANA	MEMBRAN	MEMBRANE	MEMBRANE	MEMBRANA		
22	3003082	•	•	•	•	•	•	FILTRO	FILTER	FILTRE	PUMPENFILTER	FILTRO		B
23	3003776	•	•	•	•	•	•	VITE	SCREW	VIS	SCHRAUBE	TORNILLO		
24	3003777	•	•	•	•	•	•	PERNO	BAR	GLISSIERE	BOLZEN	PERNO		C
25	3003778	•	•	•	•	•	•	ALBERINO	SHORT SHAFT	AXE	KLEINWELLE	ÁRBORILLO		
26	3003779	•	•	•	•	•	•	FOTORESISTENZA	P.E. CELL	CELLULE	FOTOWIDERSTAND	FOTORESISTENCIA		A
27	3003780	•	•	•	•	•	•	PASSACAVO	FAIRLEAD	PASSE-CABLE	KABELDURCHGANG	PASACABLES		
28	3006937	•	•	•	•	•	•	SPINA 7 POLI	7 POLE PLUG	FICHE 7 POLES	STECKER 7 POLEN	CON. HEMBRA DE 7 CONTAC.		
29	3006938	•	•	•	•	•	•	PRESA 7 POLI	7 POLE SOCKET	PRISE 7 POLES	STECKERBUCHSE 7 POLEN	CON. MACHO DE 7 CONTAC.		
30	3006949	•	•	•	•	•	•	PRESA 4 POLI	4 POLE SOCKET	PRISE 4 POLES	STECKERBUCHSE 4 POLEN	CON. MACHO DE 7 CONTAC.		
31	3003781			•	•			AVVIATORE	STARTER	DEMARREUR	ANLASSER	ARRANCADOR		C
31	3003782			•	•			AVVIATORE	STARTER	DEMARREUR	ANLASSER	ARRANCADOR		C
32	3003783	•	•	•	•	•	•	SUPPORTO	SUPPORT	SUPPORT	HALTER	SOPORTE		
33	3003784	•	•	•	•	•	•	MORSETTIERA	CONTROL BOX BASE	SOCLE	STECKSOCKEL	ZOCALO CAJA CONTROL		
34	3003785	•	•	•	•	•	•	TRASFORMATORE	TRANSFORMER	TRANSFORMATEUR	ZÜNDTRANSFORMATOR	TRANSFORMADOR		B
35														
36	3003788	•	•	•	•	•	•	SCUDO ANTERIORE	FRONT SHIELD	BOUCLIER AVANT	VORDERES SCHILD	PROTECCION		
37	3003789	•	•	•	•	•	•	PROLUNGA	EXTENSION	RALLONGE	VERLÄNGERUNG	PROLONGACIÓN		
38	3003790	•	•	•	•	•	•	PIASTRA	ANCHOR PLATE	PLATINE DE BLOCAGE	ARRETIERPLATTE	PLACA		

* = Versione Testa Lunga - Long Combustion Head Version - Version Tête Longue - Langer Brennkopf Ausführung - Version alargado de tubo llama

N.	COD.	652T1		653T1		654T1		DESCRIZIONE	DESCRIPTION	DESCRIPTION	BESCHREIBUNG	DENOMINACION	MATRICOLA BRUCIATORE BURNER SERIAL NUMBER MATRICULE BRULEUR BRENNER KENN-NUMMER MATRICULA QUEMADORES	RICAMBI CONSIGLIATI ADVISED PARTS RECHANGE CONSEIL EMPFOHLENE ERSATZTEILE RECAMBIOS ACONSEJADOS
		3473232	3473233 *	3474132	3474133 *	3474332	3474333 *							
39	3003837	•	•	•	•	•	•	TUBO	TUBE	TUYAUTERIE	DRUCKROHR	TUBO		
40	3003794	•	•	•	•	•	•	COLLEGAMENTO	H.T. LEAD	CABLE H.T.	ZÜNDKABEL	CABLES ELECTRODOS		A
40	3003795	•	•	•	•	•	•	COLLEGAMENTO	H.T. LEAD	CABLE H.T.	ZÜNDKABEL	CABLES ELECTRODOS		A
41	3003796	•	•	•	•	•	•	ELETTRODO	ELECTRODE	ELECTRODE PORCELAINE	ELEKTRODE	ELECTRODO		A
42	3003495	•	•	•	•	•	•	CAVALLOTTO	U BOLT	CAVALIER	BÜGELBOLZEN	FIJACION ELECTRODO		
43														
44	3003798	•	•	•	•	•	•	FRONTONE	FRONT PIECE	FACADE	VORDERTEIL	SOPORTE QUEMADOR		
44	3003838	•	•	•	•	•	•	FRONTONE	FRONT PIECE	FACADE	VORDERTEIL	SOPORTE QUEMADOR		
45	3003799	•	•	•	•	•	•	SQUADRETTA	SQUARE	EQUERRE-SUPPORT	HALTER	ESCUADRA		
45	3003800	•	•	•	•	•	•	SQUADRETTA	SQUARE	EQUERRE-SUPPORT	HALTER	ESCUADRA		
45	3003801	•	•	•	•	•	•	SQUADRETTA	SQUARE	EQUERRE-SUPPORT	HALTER	ESCUADRA		
45	3003802	•	•	•	•	•	•	SQUADRETTA	SQUARE	EQUERRE-SUPPORT	HALTER	ESCUADRA		
45	3003803	•	•	•	•	•	•	SQUADRETTA	SQUARE	EQUERRE-SUPPORT	HALTER	ESCUADRA		
45	3003804	•	•	•	•	•	•	SQUADRETTA	SQUARE	EQUERRE-SUPPORT	HALTER	ESCUADRA		
46	3003805	•	•	•	•	•	•	OTTURATORE	SHUTTER	OBTURATEUR	SCHIEBER	OBTURADOR		C
46	3003806	•	•	•	•	•	•	OTTURATORE	SHUTTER	OBTURATEUR	SCHIEBER	OBTURADOR		C
47	3003807	•	•	•	•	•	•	IMBUTO FIAMMA	END CONE	EMBOUT GUEULARD	FLAMMENROHR	TUBO EXTREMO		B
47	3003808	•	•	•	•	•	•	IMBUTO FIAMMA	END CONE	EMBOUT GUEULARD	FLAMMENROHR	TUBO EXTREMO		B
47	3003809	•	•	•	•	•	•	IMBUTO FIAMMA	END CONE	EMBOUT GUEULARD	FLAMMENROHR	TUBO EXTREMO		B
47	3003810	•	•	•	•	•	•	IMBUTO FIAMMA	END CONE	EMBOUT GUEULARD	FLAMMENROHR	TUBO EXTREMO		B
47	3003811	•	•	•	•	•	•	IMBUTO FIAMMA	END CONE	EMBOUT GUEULARD	FLAMMENROHR	TUBO EXTREMO		B
47	3003812	•	•	•	•	•	•	IMBUTO FIAMMA	END CONE	EMBOUT GUEULARD	FLAMMENROHR	TUBO EXTREMO		B
48	3003813	•	•	•	•	•	•	SUPPORTO	SUPPORT	SUPPORT	HALTER	SOPORTE		
49	3003814	•	•	•	•	•	•	PORTASPRUZZO	NOZZLE HOLDER	PULVERISATEUR	DÜSENSTOCK	PORTABOQUILLA		C
50	3003815	•	•	•	•	•	•	SUPPORTO	SUPPORT	SUPPORT	HALTER	SOPORTE		
51	3003816	•	•	•	•	•	•	CHIAVETTA	KEY	CLAVETTE	PASSFEDER	CHAVETA		
52	3003893	•	•	•	•	•	•	GRUPPO MISURAZIONE	TEST POINT	PRISE DE PRESSION	MESSNIPPEL	GRUPO TOMA DE PRESIÓN		
53	3003817	•	•	•	•	•	•	SCHERMO	FLANGE GASKET	ECRAN THERMIQUE	FLANSCHDICHTUNG	JUNTA AISLANTE		
54	3003791	•	•	•	•	•	•	ELICA	DIFFUSER DISC	ACCROCHE FLAMME	STAUISCHEIBE	DISCO ESTABILIZADOR		A
54	3003792	•	•	•	•	•	•	ELICA	DIFFUSER DISC	ACCROCHE FLAMME	STAUISCHEIBE	DISCO ESTABILIZADOR		A
54	3003793	•	•	•	•	•	•	ELICA	DIFFUSER DISC	ACCROCHE FLAMME	STAUISCHEIBE	DISCO ESTABILIZADOR		A
55	3003820	•	•	•	•	•	•	ANELLO	PISTON SEAL	JOINT TORIQUE	LIPPENDICHTUNG	ANILLO		B
56	3003821	•	•	•	•	•	•	TUBO	TUBE	TUYAUTERIE	DRUCKROHR	TUBO		
57	3003822	•	•	•	•	•	•	TUBO	TUBE	TUYAUTERIE	DRUCKROHR	TUBO		
58	3003823	•	•	•	•	•	•	ANELLO	PISTON SEAL	JOINT TORIQUE	LIPPENDICHTUNG	ANILLO		B
59	3003824	•	•	•	•	•	•	QUADRANTE	GRADUATE SECTOR	SECTEUR GRADUE	SKALENSEGMENT	SECTOR GRADUADO		
60	3003774	•	•	•	•	•	•	TUBO	TUBE	TUYAUTERIE	DRUCKROHR	TUBO		
61	3003825	•	•	•	•	•	•	MARTINETTO	HYDRAULIC JACK	VERIN AIR	LUFTKLAPPE DRUCKKOLBEN	HIDRÀULICO DE AIRE		C
62	3003826	•	•	•	•	•	•	GRUPPO SERRANDA	AIR DAMPER ASSEMBLY	GROUPE VOLET AIR	LUFTKLAPPE	CONJUNTO REGISTRO AIRE		B
63	3003594	•	•	•	•	•	•	BOBINA	COIL	BOBINE E.V.	MV-SPULE	BOBINA		
64	3003827	•	•	•	•	•	•	COLLEGAMENTO	LEAD	CONNEXION	VERBINDUNG	CABLE CONEXION		
65	3003828	•	•	•	•	•	•	BOBINA	COIL	BOBINE E.V.	MV-SPULE	BOBINA		B
66	3003829	•	•	•	•	•	•	GUSCIO	HALF-SHELL	COUVERCLE	HAUBE	CÀSCARA		
67	3003830	•	•	•	•	•	•	FONOASSORBENTE	SOUND DAMPING	INSONORISANT	GERÄUSCHDÄMMUNG	AISLAMIENTO ACÚSTICO		

* = Versione Testa Lunga - Long Combustion Head Version - Version Tête Longue - Langer Brennkopf Ausführung - Version alargado de tubo llama

N.	COD.	652T1		653T1		654T1		DESCRIZIONE	DESCRIPTION	DESCRIPTION	BESCHREIBUNG	DENOMINACION	MATRICOLA BRUCIATORE BURNER SERIAL NUMBER MATRICULE BRULEUR BRENNER KENN-NUMMER MATRICULA QUEMADORES	RICAMBI CONSIGLIATI ADVISED PARTS RECHARGE CONSEIL EMPFOHLENE ERSATZTEILE RECAMBIOS A CONSEJADOS
		3473232	3473233 *	3474132	3474133 *	3474332	3474333 *							
68	3003831	•	•	•	•	•	•	GRUPPO VALVOLE	VALVE ASSEMBLY	GROUPE ELECTROVANNE	MAGNETVENTILBLOCK	GRUPO VÁLVULA		B
69	3003832	•	•	•	•	•	•	BOCCA D'ASPIRAZIONE	AIR INTAKE	BOITIER D'ASPIRATION	ANSAUGÖFFNUNG	BOCA ASPIRACION		
70	3003833	•	•					POMPA	PUMP	POMPE	PUMPE	BOMBA		C
70	3003834			•	•	•	•	POMPA	PUMP	POMPE	PUMPE	BOMBA		C
70	3003835					•	•	POMPA	PUMP	POMPE	PUMPE	BOMBA		C
71	3003836	•	•	•	•	•	•	TUBO	TUBE	TUYAUTERIE	DRUCKROHR	TUBO		
72	3006784	•	•	•	•	•	•	RACCORDO	CONNECTOR	MAMELON	NIPPEL	RACORD		C
73	3005804	•	•	•	•	•	•	PERNO	SCREW	VIS CREUSE	HOHLKERNSCHRAUBE	PERNO		C
74	3006788	•	•	•	•	•	•	GUARNIZIONE	SEAL	JOINT COUVERCLE POMPE	DICHTUNG	JUNTA		B
75	3012160	•	•	•	•			FILTRO ANTIDISTURBO	DEGLITCHER	FILTRE	ENTSTÖRER	FILTRO ANTI-INTERFERENCIA		
75	3012155				•	•	•	FILTRO ANTIDISTURBO	DEGLITCHER	FILTRE	ENTSTÖRER	FILTRO ANTI-INTERFERENCIA		
76	3012622	•	•	•	•	•	•	DISCO ELASTICO	DRIVE DISK	DISQUE ELASTIQUE	KUPPLUNGSSCHEIBE	DISCO ELASTICO		

* = Versione Testa Lunga - Long Combustion Head Version - Version Tête Longue - Langer Brennkopf Ausführung - Version alargado de tubo llama

**

A = Ricambi per dotazione minima - Spare parts for minimum fittings - Pièces détachées pour équipement minimum - Ersatzteile für minimale Ausstattung - Recambios para equipamiento mínimo

A+B = Ricambi per dotazione base di sicurezza - Spare parts for basic safety fittings - Pièces détachées pour équipement standard de sécurité - Ersatzteile für Sicherheitsgrundausrüstung - Recambios para equipamiento básico de seguridad

A+B+C = Ricambi per dotazione estesa di sicurezza - Spare parts for extended safety fittings - Pièces détachées pour équipement complet de sécurité - Ersatzteile für erweiterte Sicherheitsausstattung - Recambios para equipamiento general de seguridad



RIELLO S.p.A.
Via degli Alpini 1
I - 37045 Legnago (VR)
Tel.: +39.0442.630111 Fax: +39.0442.630375
[http:// www.rielloburners.com](http://www.rielloburners.com).